

Abmessungen und Bauformen (Antrieb) *Dimensions and Configurations (Input)* HighRatio Ausführung *HighRatio Design*

Antrieb mit Planetenvorstufe
Input with planetary pre-stage

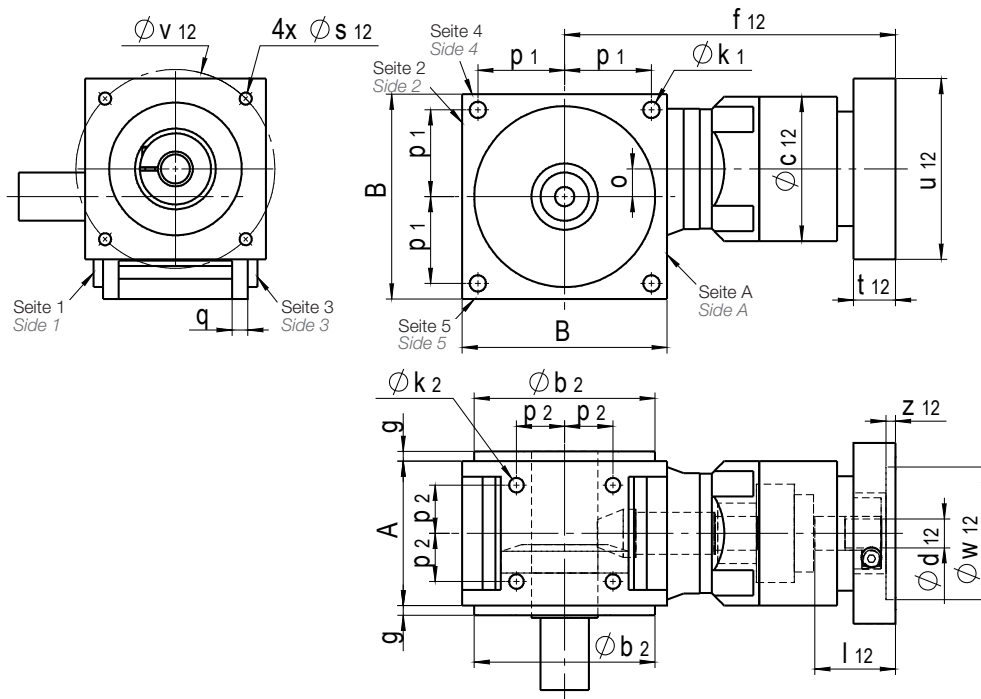

Abmessungen *Dimensions*

Größe <i>Size</i>	A	B	Øb _{g6}	g	o	p ₁	p ₂	Øk ₁	k ₂	q
D55HR	60	90	89	13,5	9	39	22	6,6	M6	8
D75HR	80	115	105	8,5	14	49	27	9	M8	10
D90HR	100	140	125	8	18	59	33	11	M10	11
D115HR	120	170	150	8	23	72	40	13,5	M12	13
D130HR	138	192	173	10	27	82	48	13,5	M12	14
D140HR	146	215	195	10	32	91	52	17,5	M16	15
D160HR	166	240	225	10	38	103	60	17,5	M16	16
D190HR	196	260	245	10	42	112	70	17,5	M16	17

Abmessungen und Bauformen (Antrieb) *Dimensions and Configurations (Input)* HighRatio Ausführung *HighRatio Design*

Antrieb mit Planetenvorstufe *Input with planetary pre-stage*

Größe <i>Size</i>	Variante <i>Variant</i>	$\varnothing d_{12}$	l_{12}	$\square u_{12}$	$\varnothing v_{12}$	$\varnothing w_{12}^{G7}$	s_{12}	f_{12}	t_{12}	z_{12}	$\varnothing c_{12}$
D55HR	V1	9	35	65	63	40	M4x9	163,5	16,5	5	63
	V2	11	35	70	75	60	M5x11	163,5	16,5	5	63
	V3	14	40	70	75	60	M6x13	168,5	21,5	10	63
	V4	14	35	80	95	50	M6x13	163,5	16,5	5	63
	V5	14	35	90	100	80	M6x13	163,5	16,5	5	63
D75HR	V1	11	40	70	75	60	M6x13	203,5	21,5	10	91
	V2	14	40	70	75	60	M6x13	203,5	21,5	10	91
	V3	14	35	80	95	50	M6x13	198,5	16,5	5	91
	V4	14	35	90	100	80	M6x13	198,5	16,5	5	91
	V5	19	50	90	100	80	M6x13	208,5	25	6	91
	V6	19	50	115	130	95	M8x17	208,5	25	6	91
	V7	19	50	100	115	95	M8x17	208,5	25	6	91
	V8	24	67	115	130	110	M8x17	225,5	35	8	91
D90HR	V1	14	40	70	75	60	M6x13	220,5	21,5	10	91
	V2	14	35	80	95	50	M6x13	215,5	16,5	5	91
	V3	14	35	90	100	80	M6x13	215,5	16,5	5	91
	V4	19	50	90	100	80	M6x13	225,5	25	6	91
	V5	19	50	115	130	95	M8x17	225,5	25	6	91
	V6	19	50	100	115	95	M8x17	225,5	25	6	91
	V7	24	67	115	130	110	M8x17	242,5	35	8	91
D115HR	V1	19	50	100	115	95	M8x17	257,5	25	6	120
	V2	19	50	115	130	95	M8x17	257,5	25	6	120
	V3	24	67	115	130	110	M8x17	274,5	35	8	120
	V4	19	60	150	165	130	M10x21	267,5	35	16	120
	V5	24	67	150	165	110	M10x21	274,5	35	8	120
	V6	32	82	150	165	130	M10x21	295,5	45	8	120
	V7	32	82	180	215	130	M10x21	295,5	45	8	120
D130HR	V1	19	50	100	115	95	M8x17	273,5	25	6	120
	V2	19	50	115	130	95	M8x17	273,5	25	6	120
	V3	24	67	115	130	110	M8x17	290,5	35	8	120
	V4	19	60	150	165	130	M10x21	283,5	35	16	120
	V5	24	67	150	165	110	M10x21	290,5	35	8	120
	V6	32	82	150	165	130	M10x21	311,5	45	8	120
	V7	32	82	180	215	130	M10x21	311,5	45	8	120
D140HR	V1	24	67	150	165	130	M10x21	321	35	8	155
	V2	24	67	150	165	110	M10x21	321	35	8	155
	V3	32	82	150	165	130	M10x21	336	45	8	155
	V4	32	82	180	215	130	M12x25	336	45	8	155
	V5	32	82	200	215	180	M12x25	336	45	8	155
	V6	38	82	200	215	180	M12x25	336	45	8	155
D160HR	V1	32	82	150	165	130	M10x21	357	45	8	155
	V2	32	82	200	215	180	M12x25	357	45	8	155
	V3	32	82	180	215	130	M12x25	357	45	8	155
	V4	38	82	200	215	180	M12x25	357	45	8	155
	V5	48	98	200	215	180	M12x25	378	55	8	155
D190HR	V1	32	82	150	165	130	M10x21	376	45	8	155
	V2	32	82	200	215	180	M12x25	376	45	8	155
	V3	38	82	180	215	130	M12x25	376	45	8	155
	V4	48	98	200	215	180	M12x25	397	55	8	155



Abmessungen und Bauformen (Abtrieb) *Dimensions and Configurations (Output)* HighRatio Ausführung *HighRatio Design*

Abtrieb mit Vollwelle *Output with solid shaft*

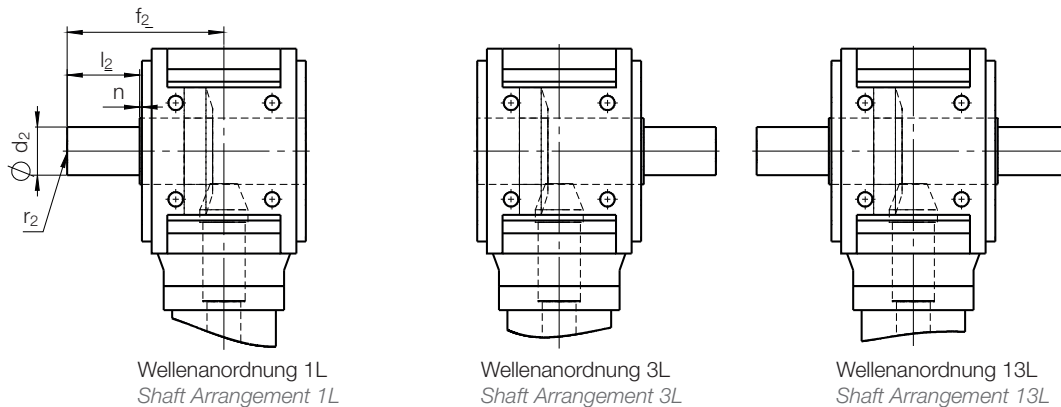

Wellenanordnung 1L
Shaft Arrangement 1L

Wellenanordnung 3L
Shaft Arrangement 3L

Wellenanordnung 13L
Shaft Arrangement 13L

Abtrieb mit Hohlwelle *Output with hollow shaft*

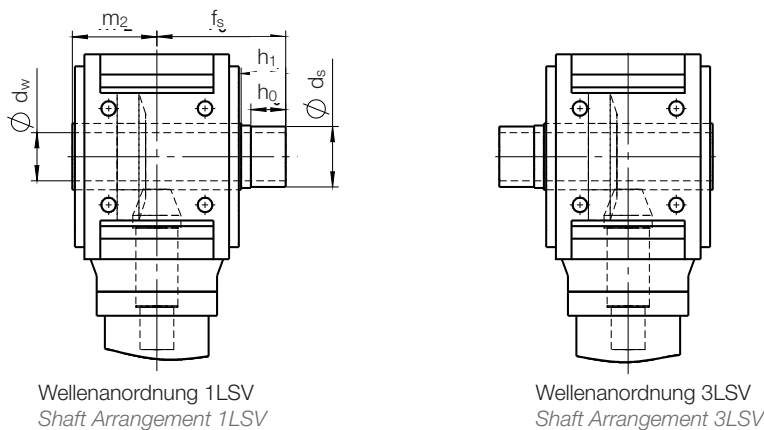

Wellenanordnung 1LSV
Shaft Arrangement 1LSV

Wellenanordnung 3LSV
Shaft Arrangement 3LSV

Abtrieb mit Vollwelle/Hohlwelle *Output with solid/hollow shaft*

Abtrieb <i>Output</i>	mit Vollwelle <i>with solid shaft</i>					mit Hohlwelle <i>with hollow shaft</i> ②					
	Größe <i>Size</i>	$\varnothing d_2$ k6	l_2	f_2	n	r_2 ①	$\varnothing d_w$ H7	$\varnothing d_s$ f7	h_0	h_1	f_s
D55HR	20	35	80	1,5	M6	20	24	20	25	71,5	45
D75HR	24	40	90	1,5	M8	25	30	22	27	79,5	50
D90HR	32	50	110	2	M12	30	36	26	31	93	60
D115HR	40	60	130	2	M16	40	50	29	34	107	70
D130HR	48	75	156	2	M16	48	55	32	37	121	81
D140HR	55	90	175	2	M20	55	68	32	38	127	85
D160HR	60	100	195	2	M20	60	75	34	41	139	95
D190HR	70	110	220	2	M20	70	80	34	41	159	110

① nach Form D DIN 332

② Welle verlängert für eine Schrumpfscheibe (z. B. Stüwe – Typ HSD 22)
Lieferung einschliesslich Schrumpfscheibe auf Anfrage

Konstruktionsänderungen vorbehalten

① According to form D DIN 332

② Extended shaft for shrink disc (e.g. Stüwe – Type HSD 22)
Delivery with shrink disc on request

Subject to design modifications

Abmessungen und Bauformen (Abtrieb) *Dimensions and Configurations (Output)*
 HighRatio Ausführung *HighRatio Design*

Abtrieb mit Roboterflansch
Output with robot flange

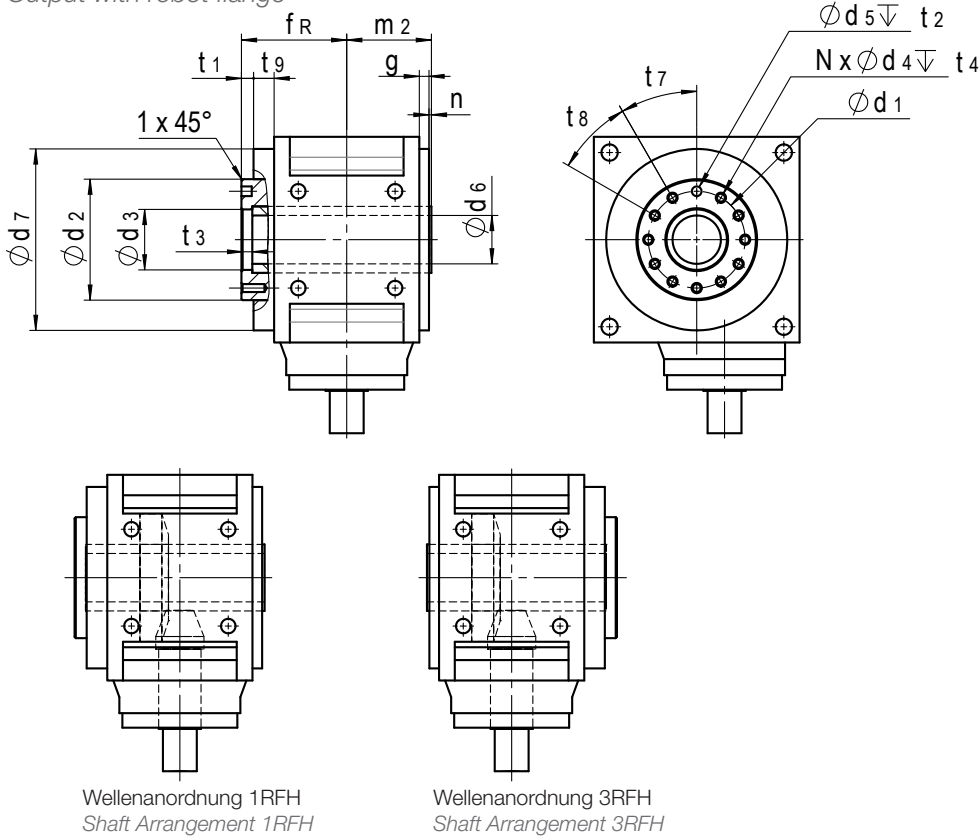

Abtrieb mit Roboterflansch gemäß EN ISO 9409-1 und Hohlwelle
Output with robot flange according to EN ISO 9409-1 and hollow shaft

Größe Size	Position Position	Teilkreis Pitch circle Ød ₁		Ød ₂ ^{H8}	Ød ₃ ^{H7}	d ₄	Ød ₅ ^{H7}	Ød ₆	Ød ₇	f _R	m ₂
		Serie 1 Series 1	Serie 2 Series 2								
D55HR	3	40	-	50	25	M6	6	18	89	57	45
D75HR	4	-	50	63	31,5	M6	6	24	105	62,5	50
D90HR	5	63	-	80	40	M6	6	28	125	73	60
D115HR	6	-	80	100	50	M8	8	40	150	87	70
D130HR	6	-	80	100	50	M8	8	40	173	96,5	81
D140HR	7	100	-	125	63	M8	8	52	195	100,5	85
D160HR	7	100	-	125	63	M8	8	52	225	115	95
D190HR	8	-	125	160	80	M10	10	65	245	132,5	110

Größe Size	g	n	t ₁	t ₂	t ₃	t ₄	t ₇	t ₈	t ₉	N
D55HR	13,5	1,5	7	6,5	7	Gewindetiefe Thread depth > 1,5x d ₄	45°	45°	20	7
D75HR	8,5	1,5	7	6,5	7		45°	45°	15,5	7
D90HR	8	2	7	6,5	7		45°	45°	16	7
D115HR	8	2	10	8,5	8,5		30°	30°	17	11
D130HR	10	2	10	8,5	8,5		30°	30°	17,5	11
D140HR	10	2	10	8,5	8,5		30°	30°	17,5	11
D160HR	10	2	12	8,5	8,5		30°	30°	20	11
D190HR	10	2	12	10,5	8,5		30°	30°	22,5	11